

NOTES:
 1. INTERPRET DIMENSIONS AND TOLERANCES AS PER ANSI Y14.5 1994.

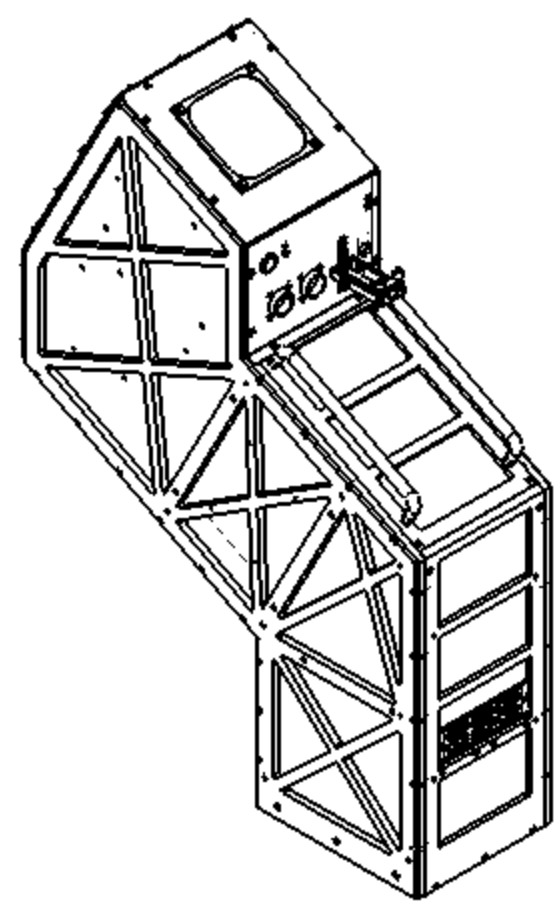
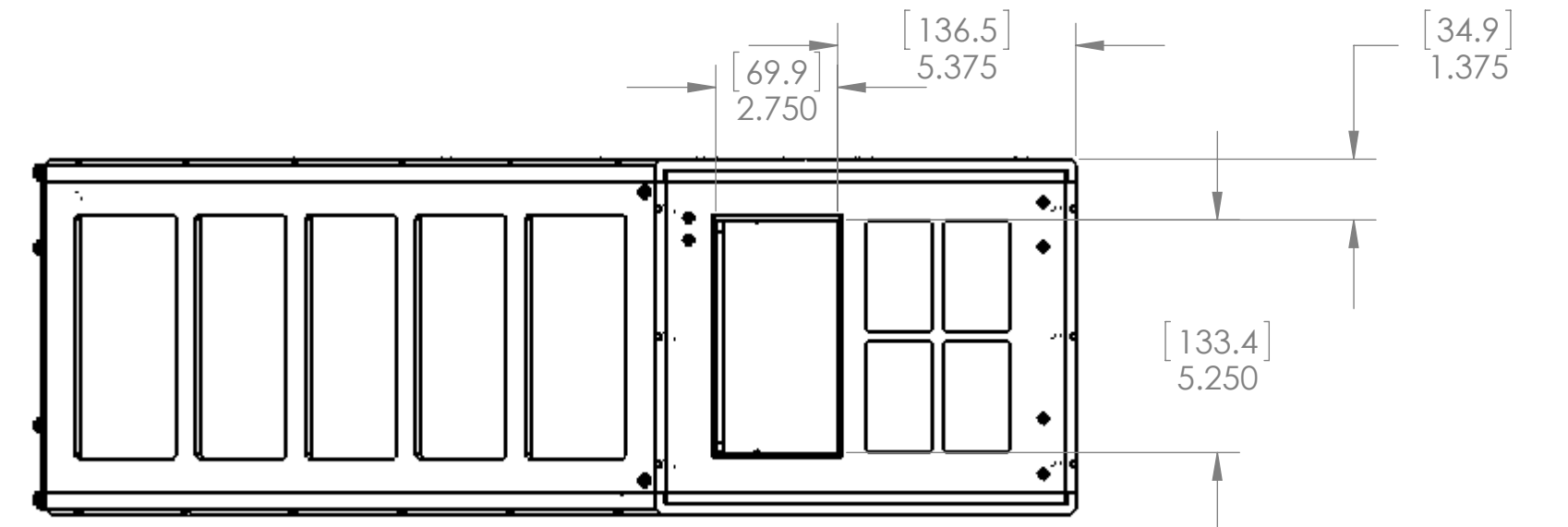
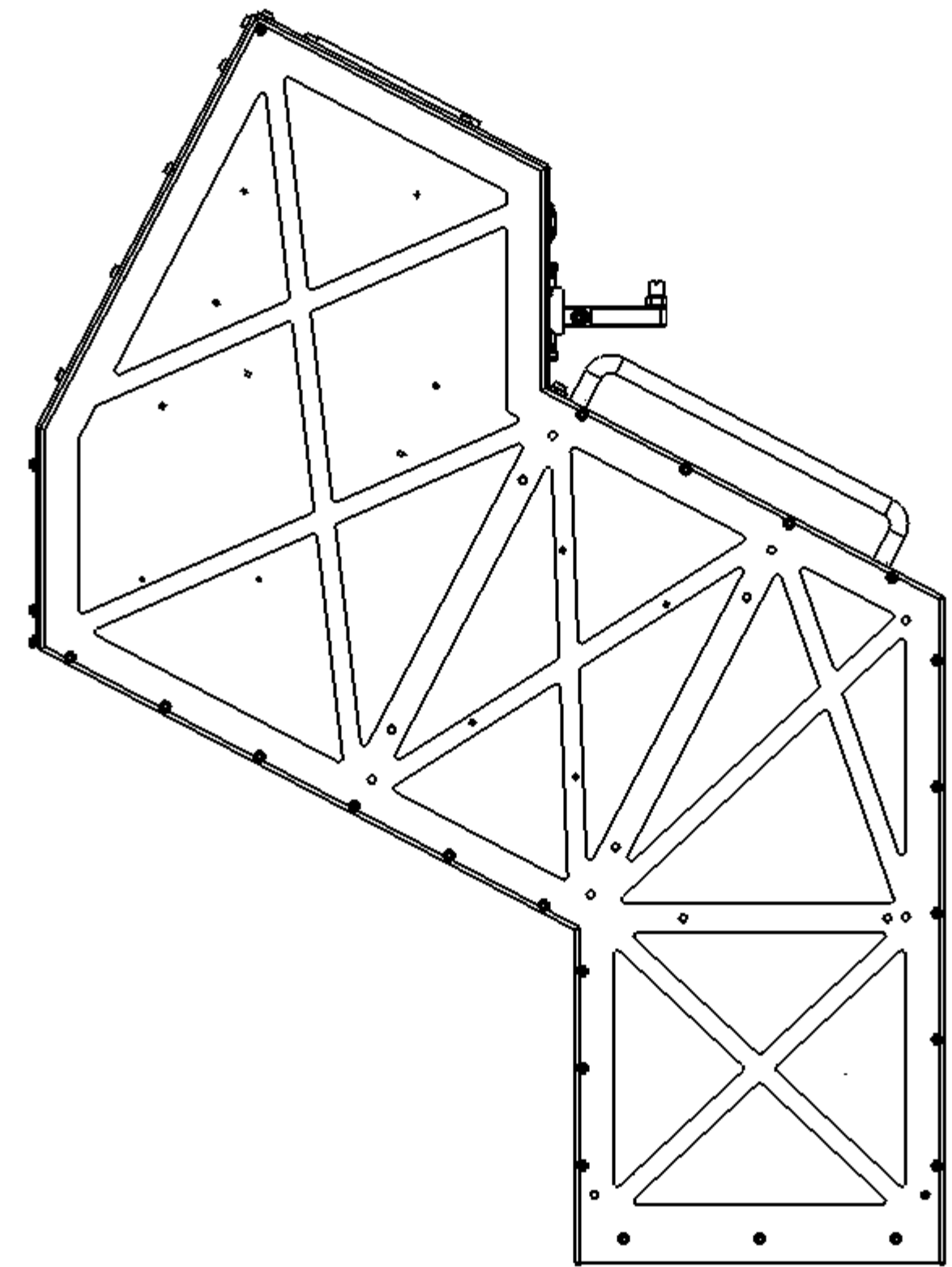
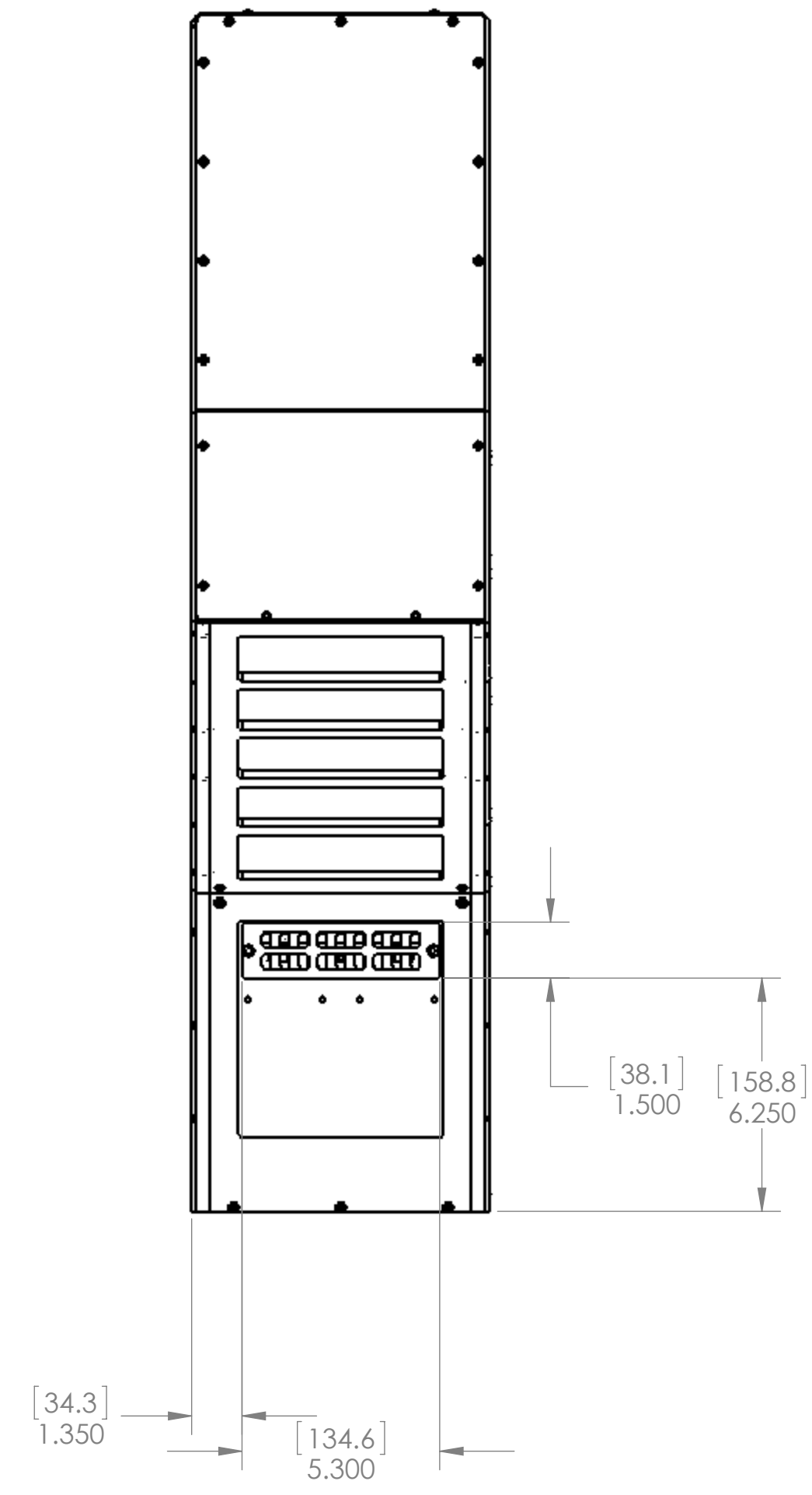
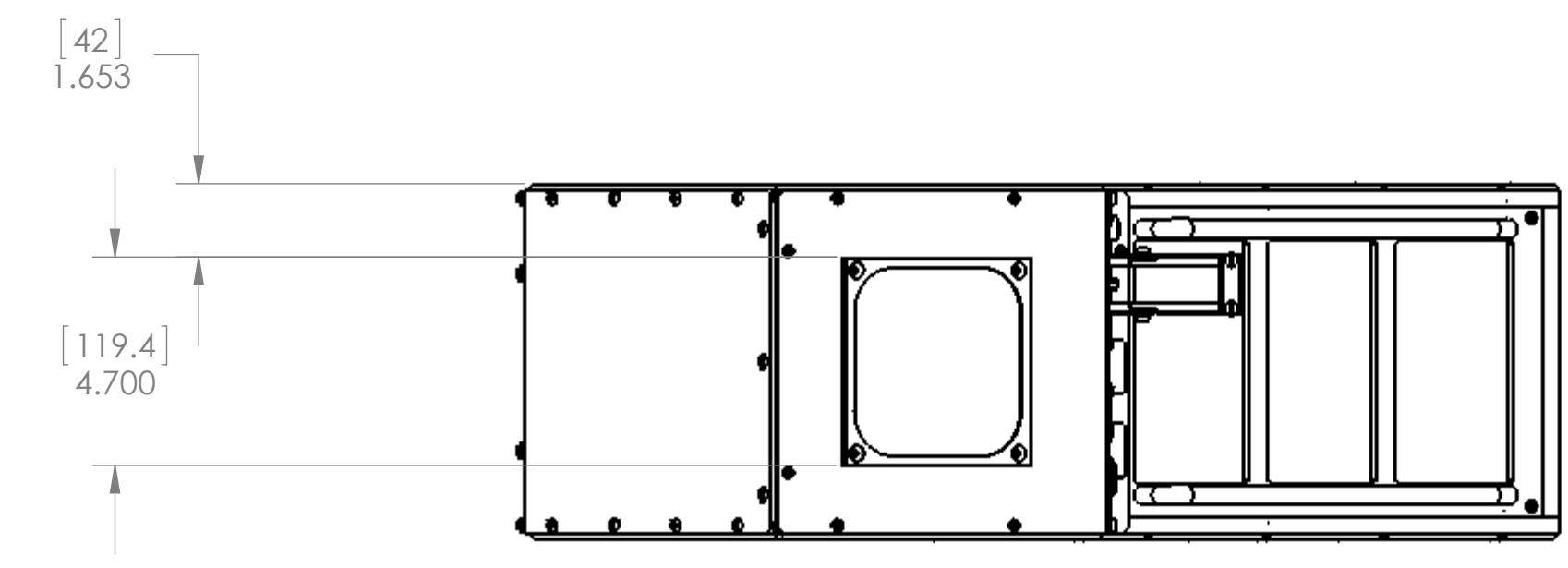
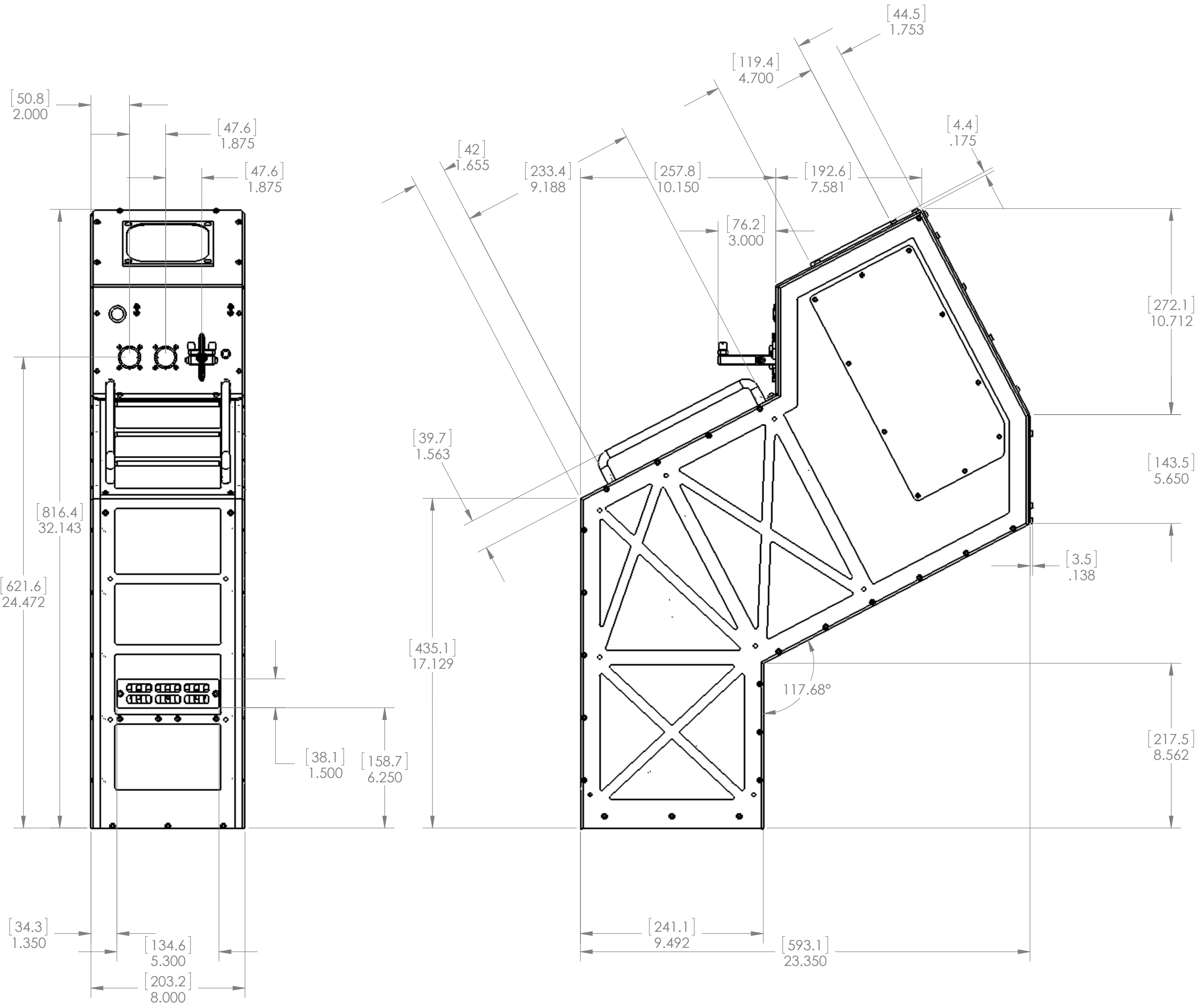

PROPRIETARY AND CONFIDENTIAL
 THE INFORMATION CONTAINED IN THIS DRAWING IS THE SOLE PROPERTY OF IRES RESEARCH LIMITED. ANY REPRODUCTION IN PART OR AS A WHOLE WITHOUT THE WRITTEN PERMISSION OF IRES RESEARCH LIMITED IS PROHIBITED.

UNLESS OTHERWISE SPECIFIED: DIMENSIONS ARE IN INCHES TOLERANCES: FRACTIONAL ± 1/32 ANGULAR ± 5 DEGREE TWO PLACE DECIMAL ± .01 THREE PLACE DECIMAL ± .005 SURFACE FINISH: 63 OR LESS		DRAWN 1/28/2014	DATE	NAME FH
CHECKED	ENG APPR.	MFG APPR.	G.A.	COMMENTS:
NEXT ASSY	USED ON	MATERIAL N/A	FINISH N/A	
APPLICATION				

ires 110, 3553 31ST STREET NW
 CALGARY, ALBERTA T2L 2K7
 TEL: 403 250 9944
 FAX: 403 250 9916

TITLE:
SENSOR HEAD UNIT, TASI 600

SIZE DWG. NO. REV
D 02054003 0

SCALE: 1:4 WT: N/A SHEET 1 OF 1

02054003

NOTES:
 1. INTERPRET DIMENSIONS AND TOLERANCES AS PER ANSI Y14.5 1994.

REVISIONS				
ZONE	REV.	DESCRIPTION	DATE	APPROVED
	1	REMOVED FAN	12/2/2013	FH

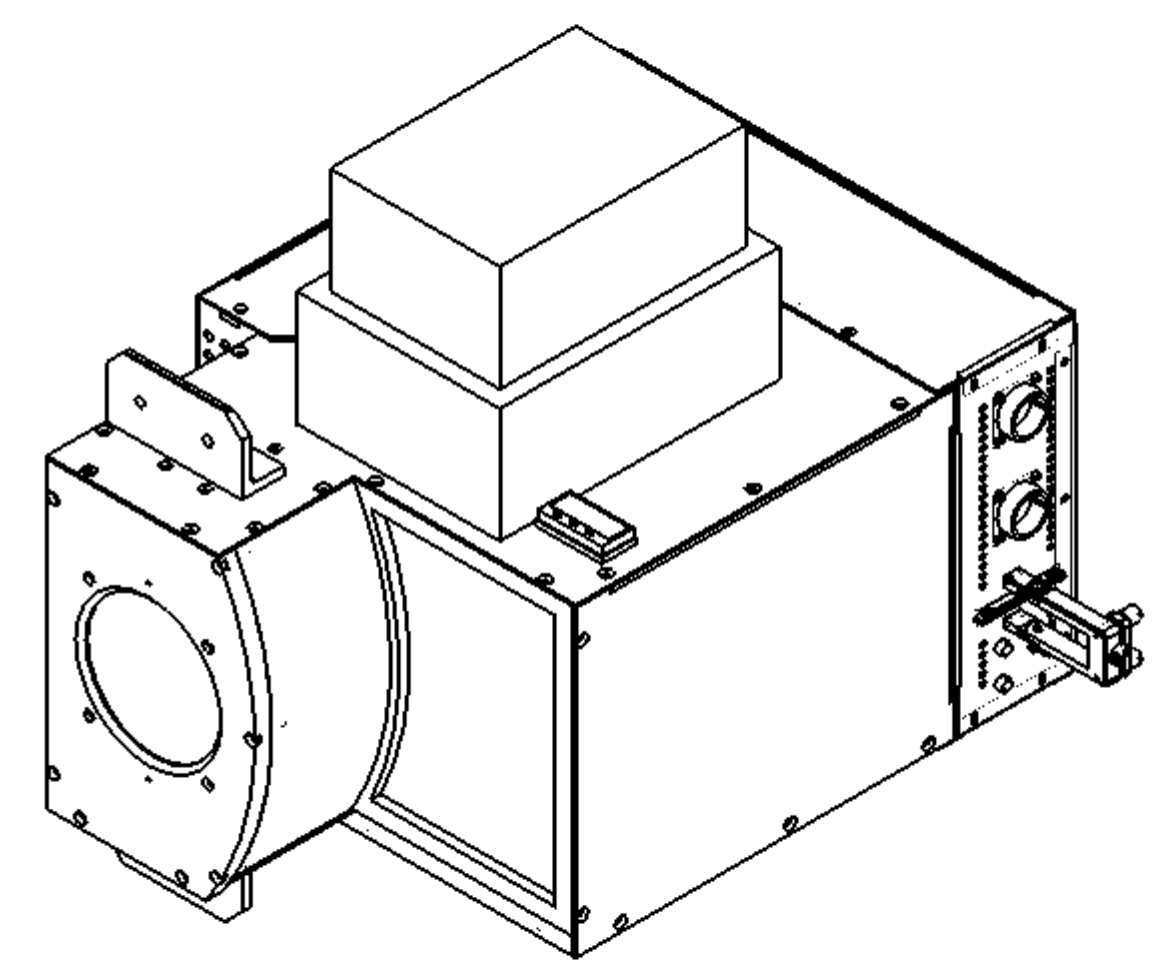
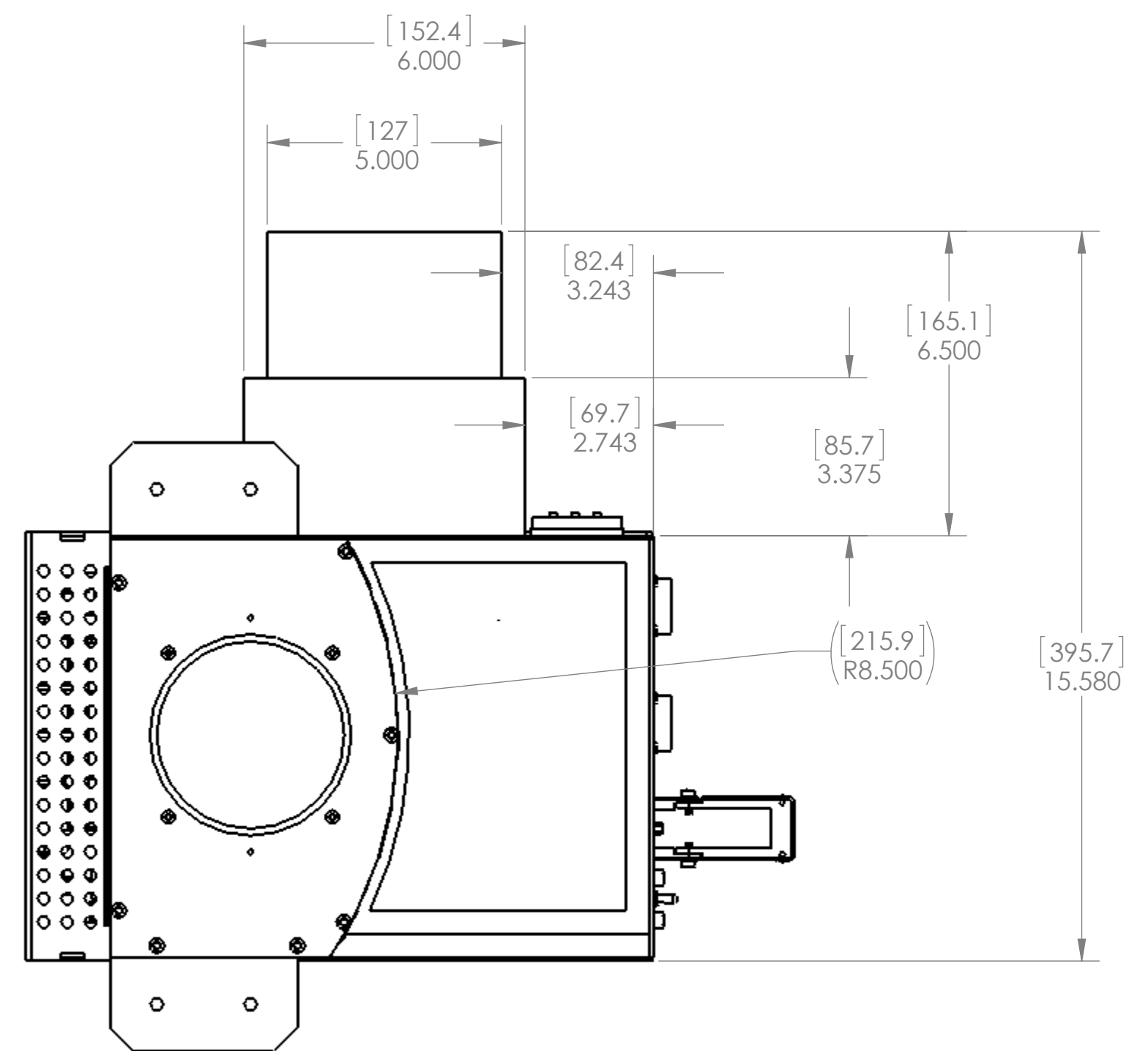
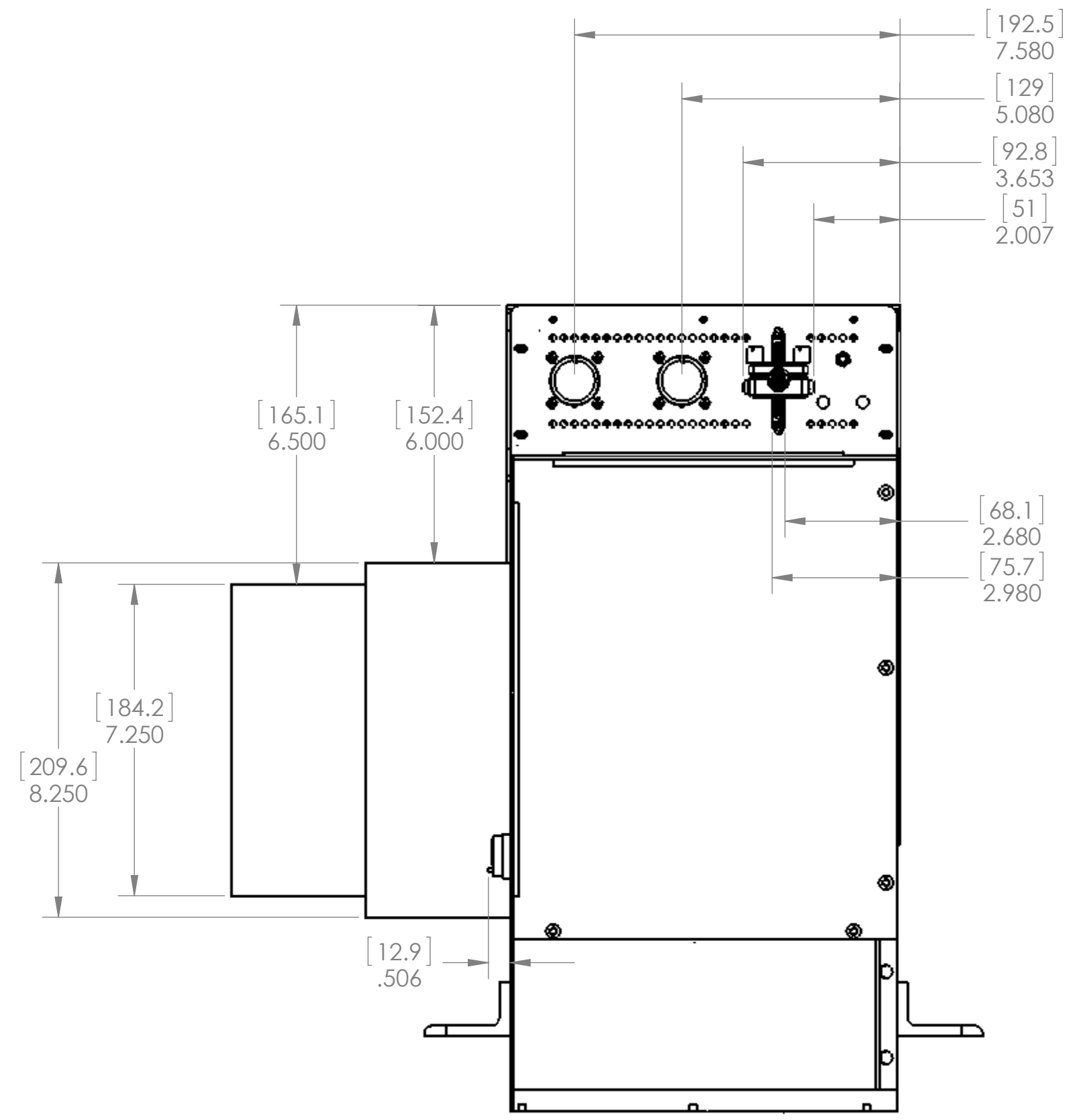
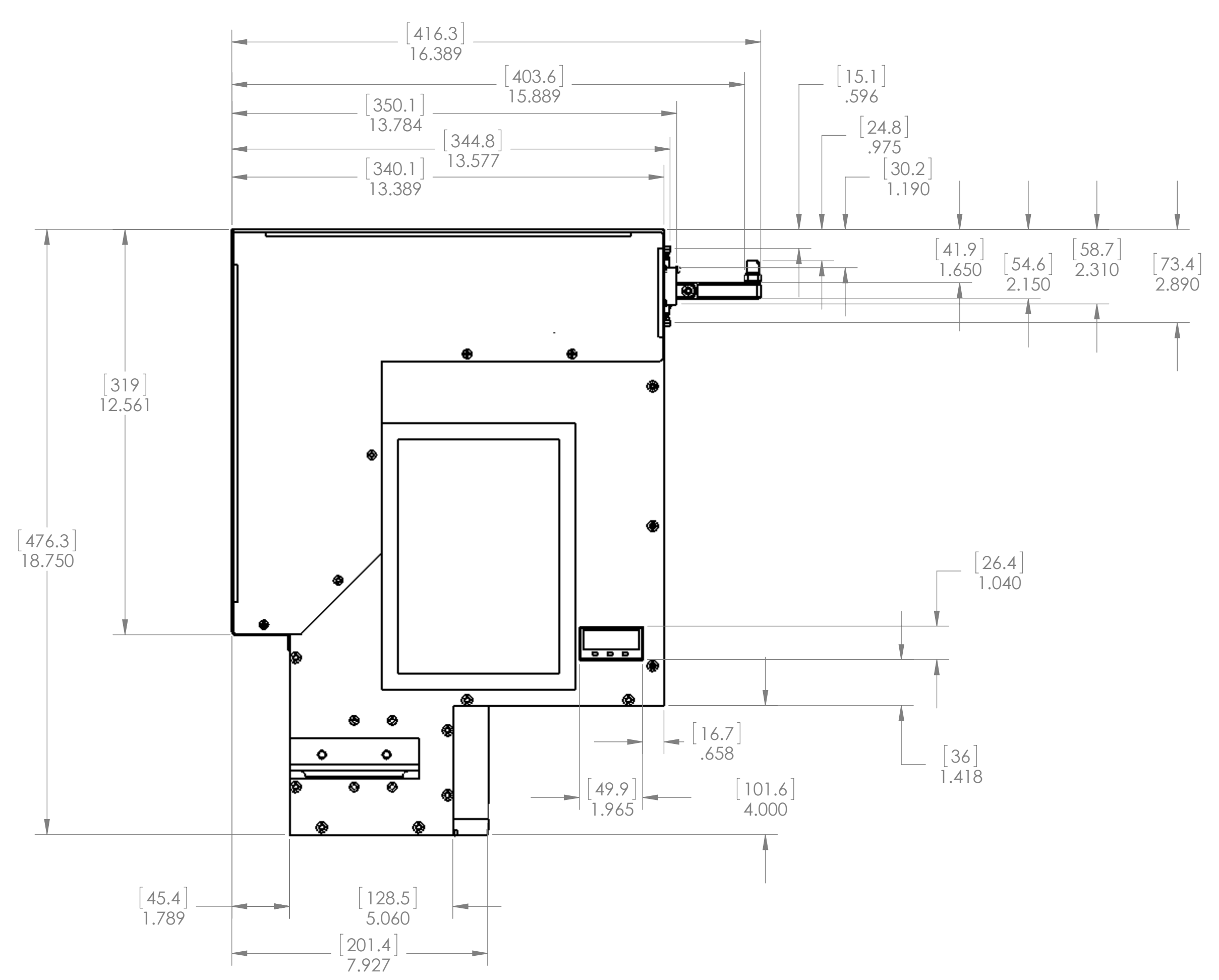

PROPRIETARY AND CONFIDENTIAL
 THE INFORMATION CONTAINED IN THIS DRAWING IS THE SOLE PROPERTY OF ITRES RESEARCH LIMITED. ANY REPRODUCTION IN PART OR AS A WHOLE WITHOUT THE WRITTEN PERMISSION OF ITRES RESEARCH LIMITED IS PROHIBITED.

DIMENSIONS ARE IN INCHES TOLERANCES: FRACTIONAL ± 1/32 ANGULAR ± 5 DEGREE TWO PLACE DECIMAL ± .01 THREE PLACE DECIMAL ± .005 SURFACE FINISH: 63 OR LESS		DRAWN 9/29/2009	DATE	NAME FH	 110, 3553 31ST STREET NW CALGARY, ALBERTA T2L 2K7 TEL: 403 250 9944 FAX: 403 250 9916
MATERIAL N/A		CHECKED	ENG APPR.	TITLE:	
NEXT ASSY USED ON APPLICATION		FINSH N/A	ENG APPR.	MFG APPR.	SIZE DWG. NO. REV D 02073500 1 SCALE: 1:3 WT: SHEET 1 OF 1

NOTES:
 1. INTERPRET DIMENSIONS AND TOLERANCES AS PER ANSI Y14.5 1994.

REVISIONS				
ZONE	REV.	DESCRIPTION	DATE	APPROVED

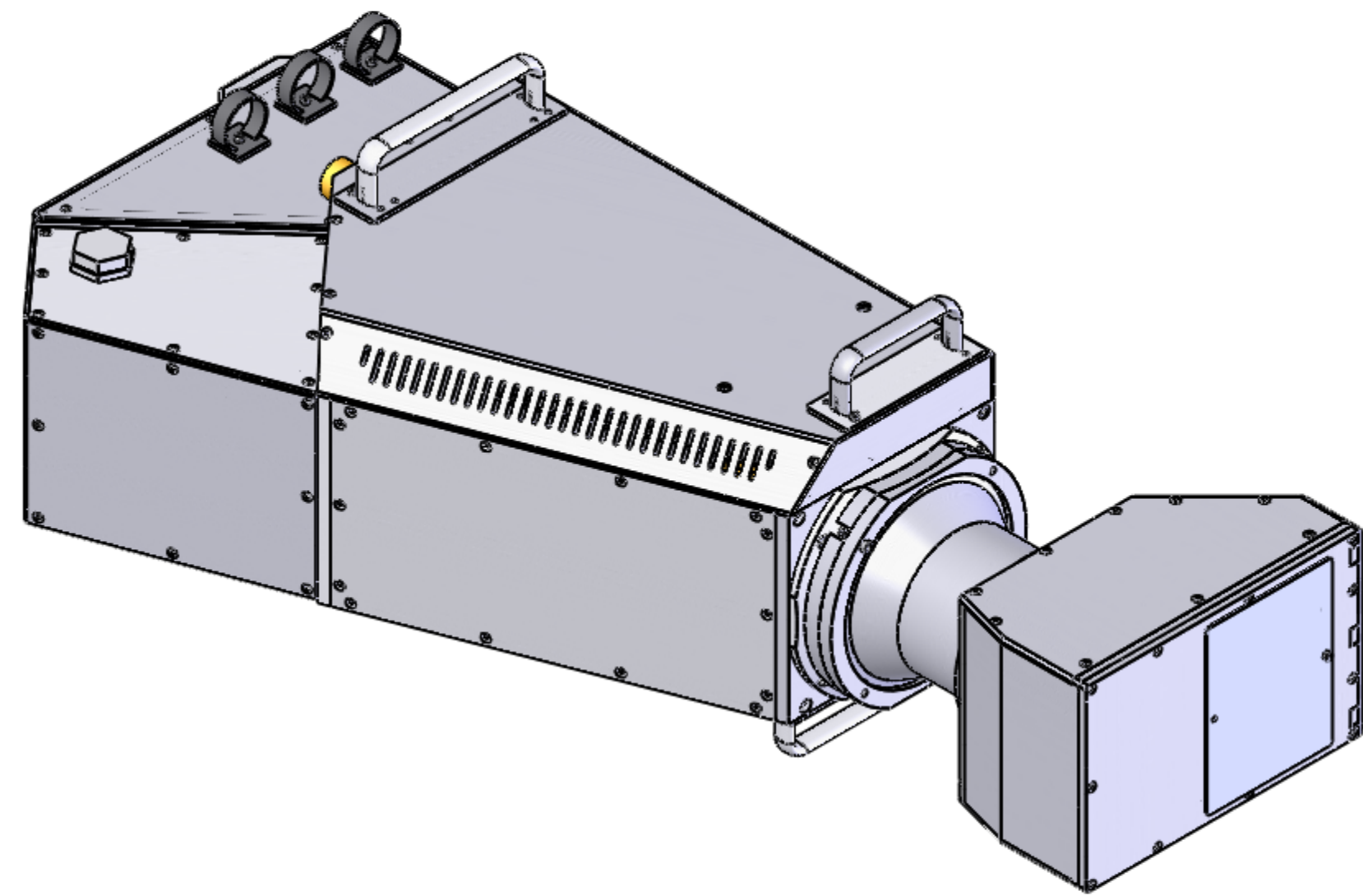

SCALE: 1:4

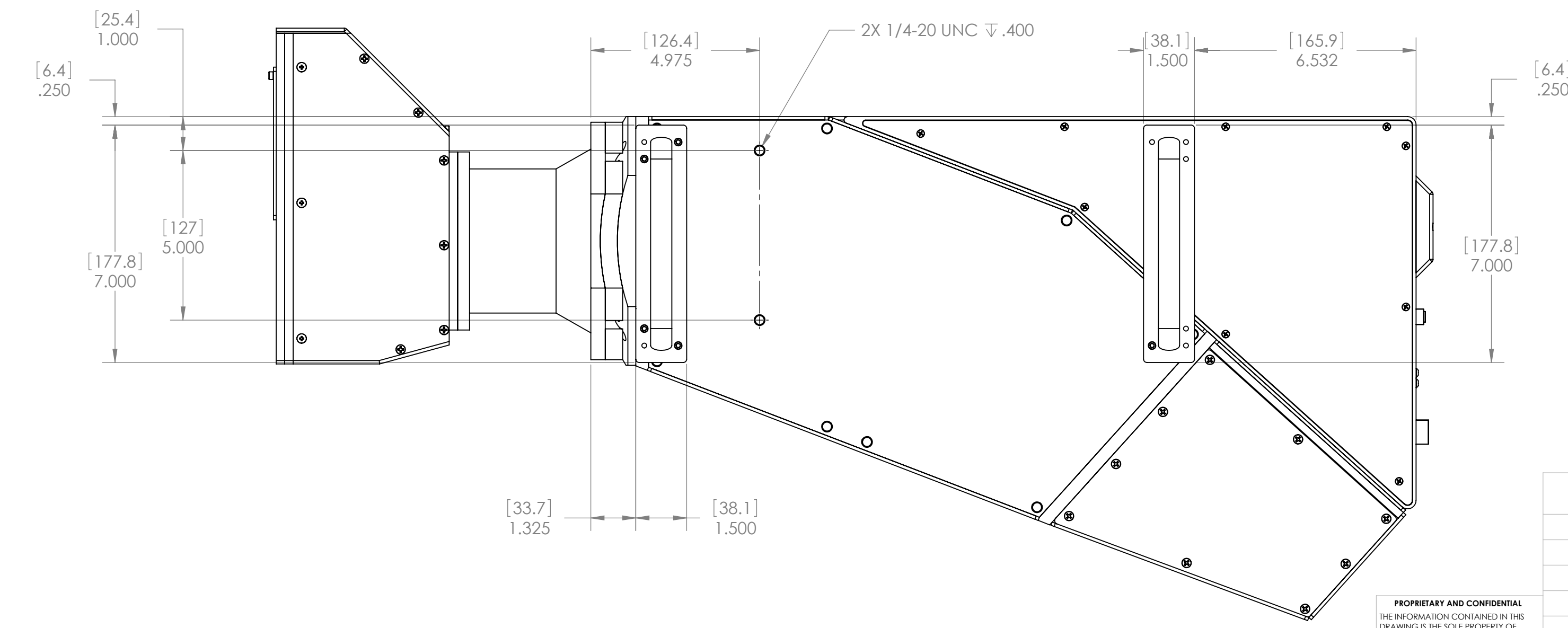
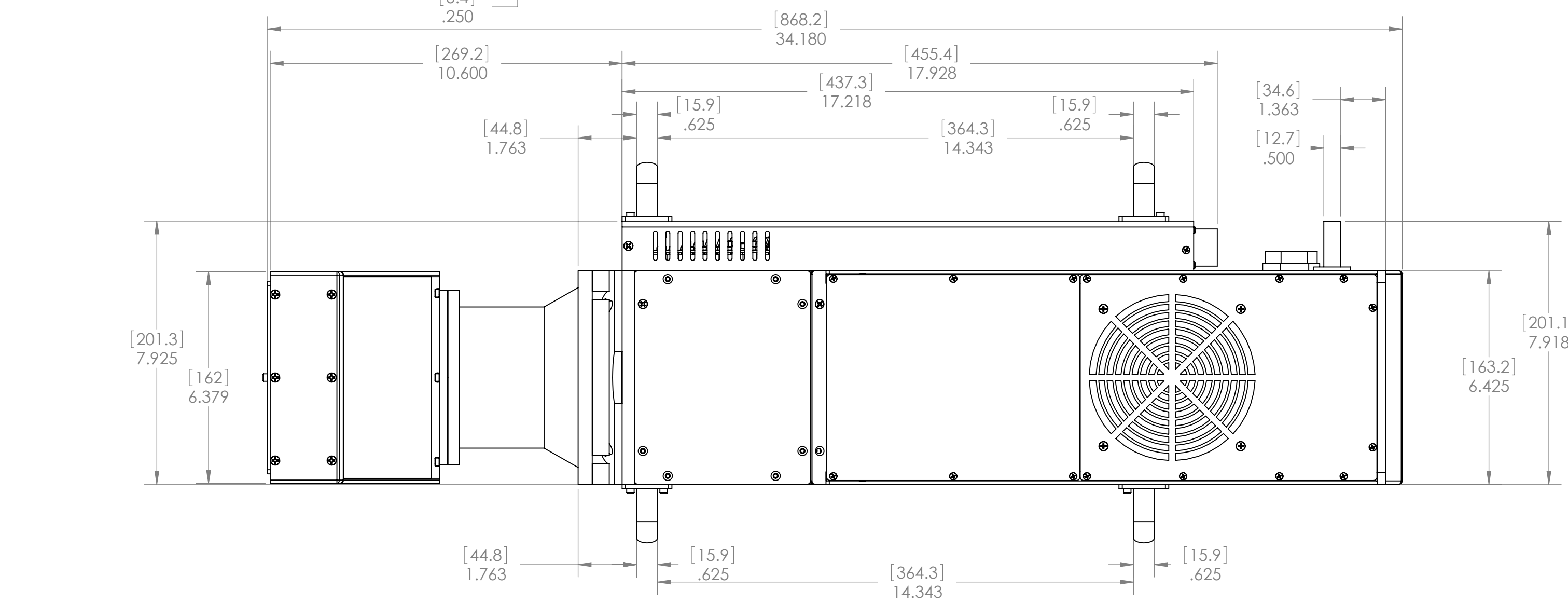
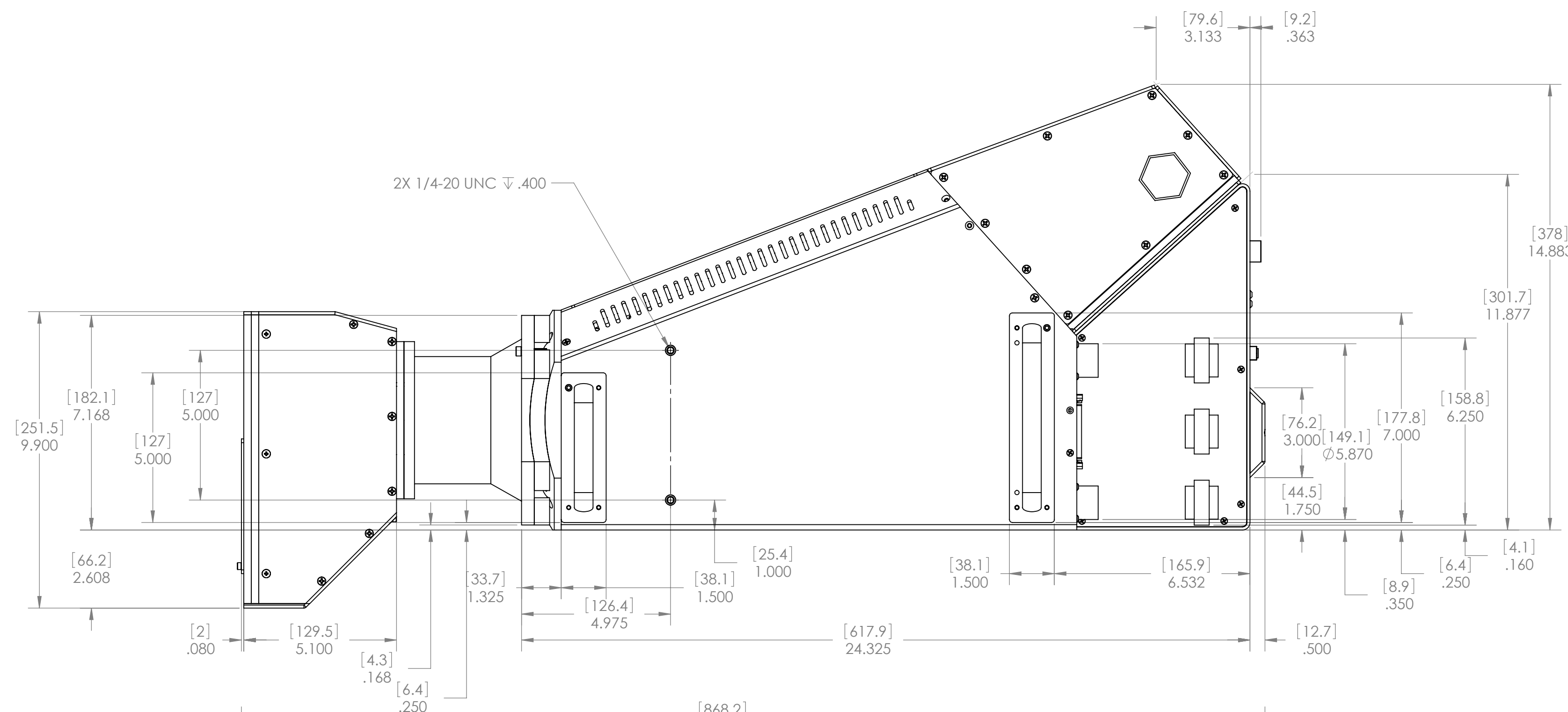
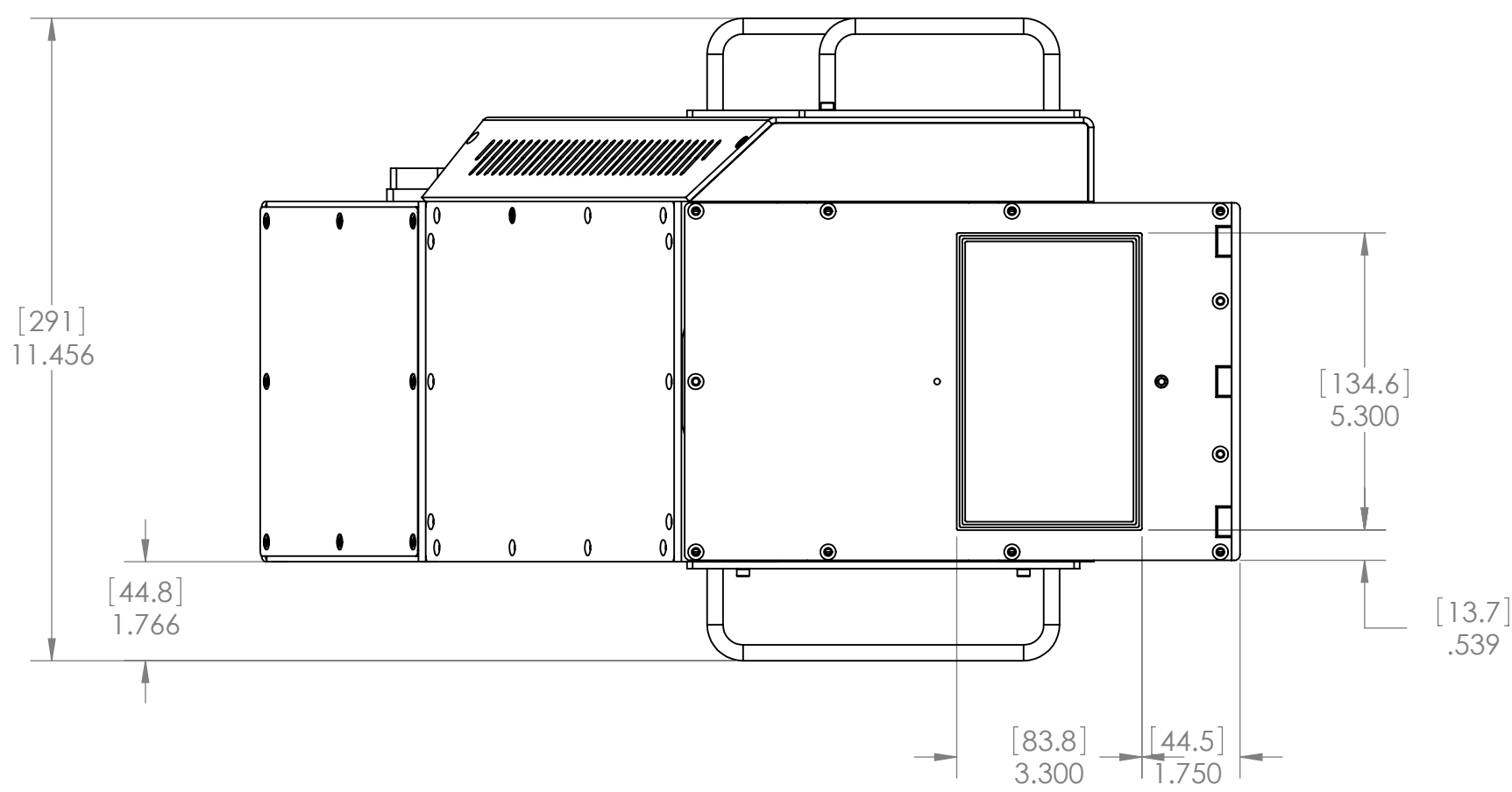

PROPRIETARY AND CONFIDENTIAL
 THE INFORMATION CONTAINED IN THIS DRAWING IS THE SOLE PROPERTY OF IRES RESEARCH LIMITED. ANY REPRODUCTION IN PART OR AS A WHOLE WITHOUT THE WRITTEN PERMISSION OF IRES RESEARCH LIMITED IS PROHIBITED.

UNLESS OTHERWISE SPECIFIED: DIMENSIONS ARE IN INCHES TOLERANCES: FRACTIONAL \pm 1/32 ANGULAR: \pm 5 DEGREE TWO PLACE DECIMAL: \pm .01 THREE PLACE DECIMAL: \pm .005 SURFACE FINISH: 63 OR LESS		DATE	NAME	 110, 3553 31ST STREET NW CALGARY, ALBERTA T2L 2K7 TEL: 403 250 9944 FAX: 403 250 9916
DRAWN	9/15/2009	MX	TITLE:	
CHECKED	9/15/2009	FH	SHU, SASI 600 ii, ROTATED OPTICS	
ENG APPR:				
MFG APPR:				
G.A.				
COMMENTS:				
MATERIAL:	N/A			
FINISH:	N/A			
NEXT ASSY:	USED ON:			
APPLICATION:				

SIZE: D
 DWG. NO.: 02054102
 SCALE: 1:3
 WT: SHEET 1 OF 1

02054102

NOTES:

1. INTERPRET DIMENSIONS AND TOLERANCES AS PER ANSI Y14.5 1994.
2. REMOVE ALL BURRS AND SHARP EDGES.

REVISIONS				
ZONE	REV.	DESCRIPTION	DATE	APPROVED
	1	REMOVED 14004400, ADDED 1405100 AND 02085700		FH

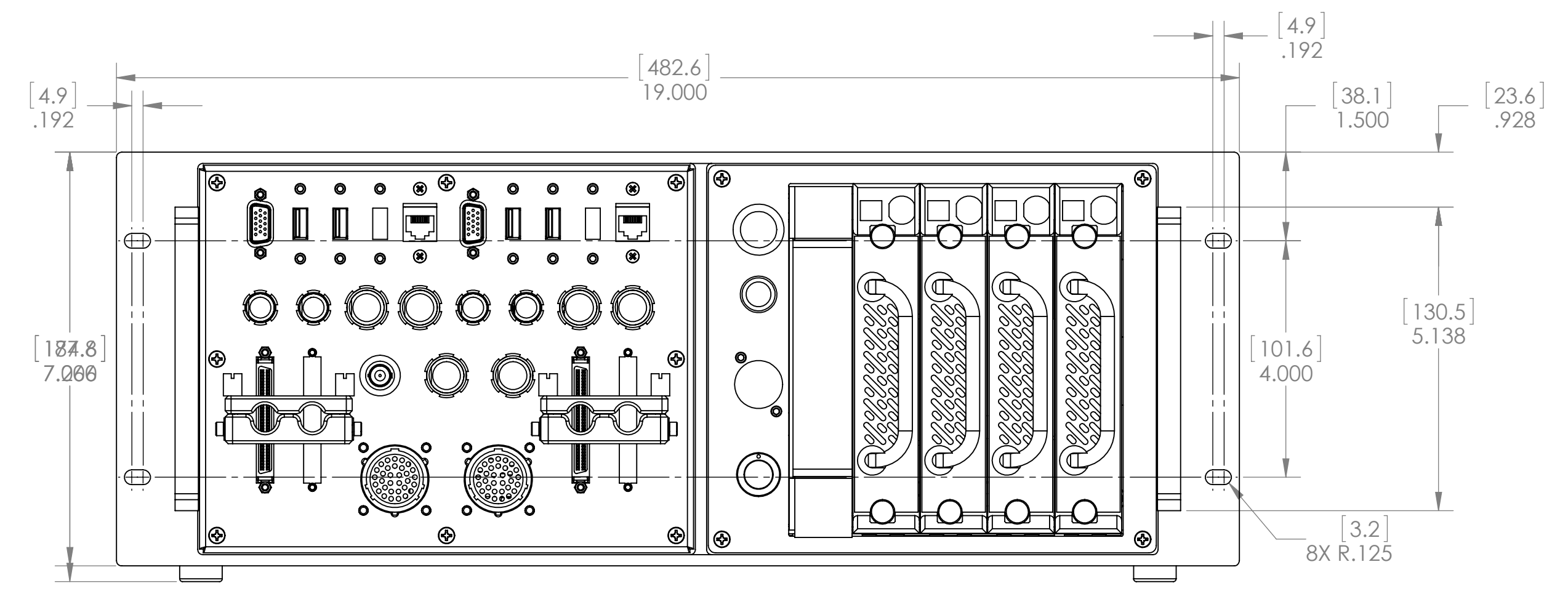
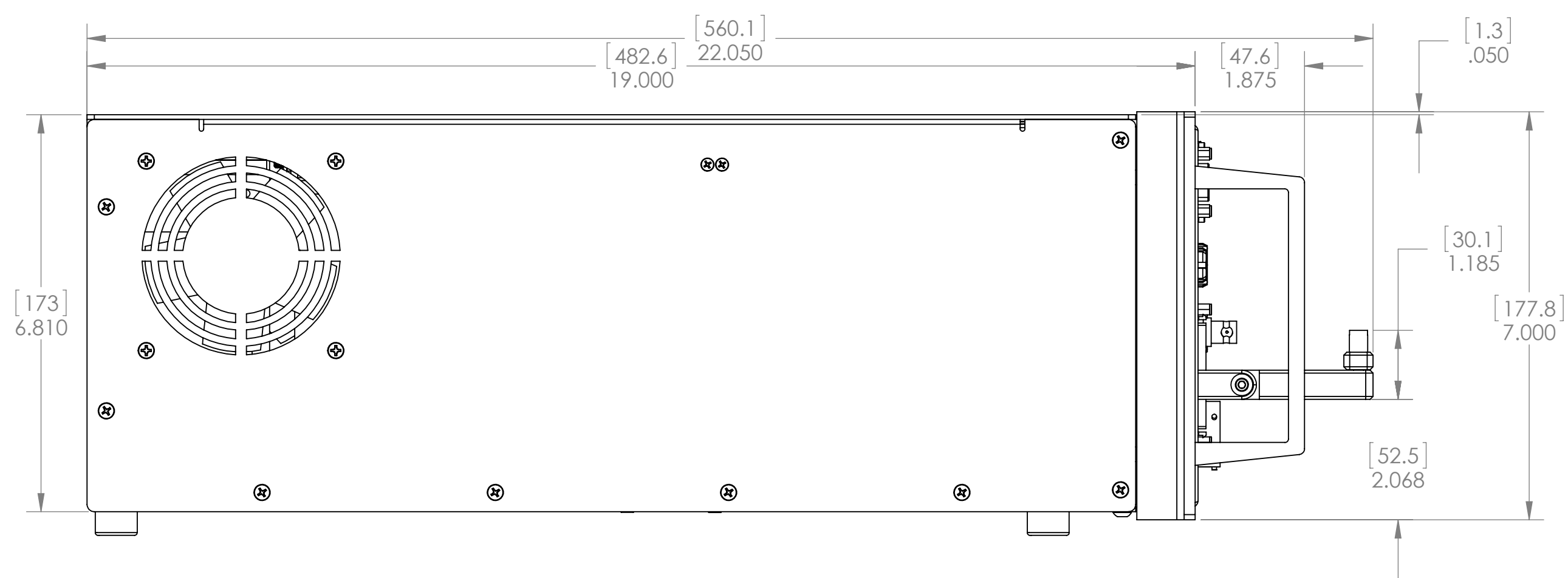
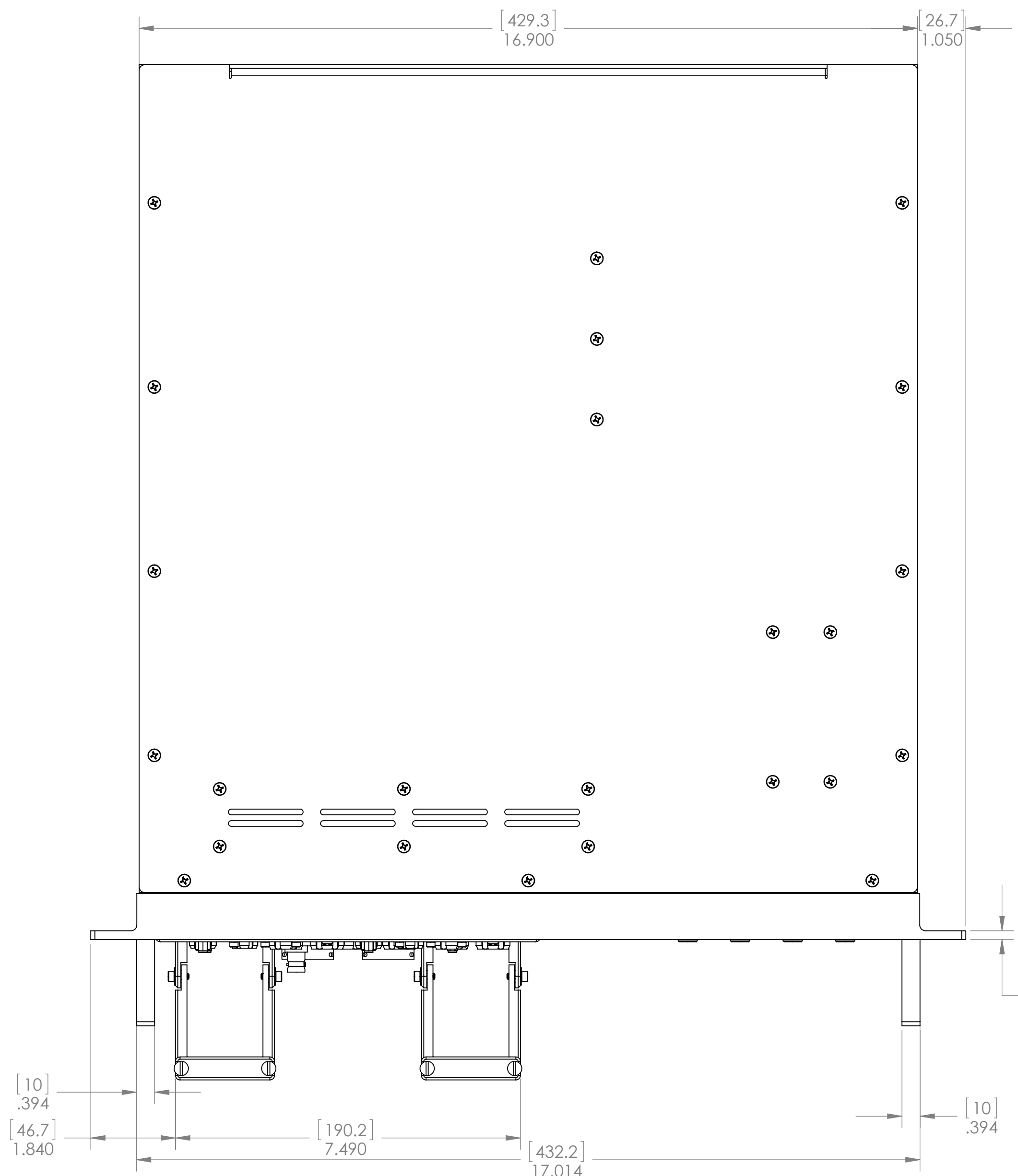
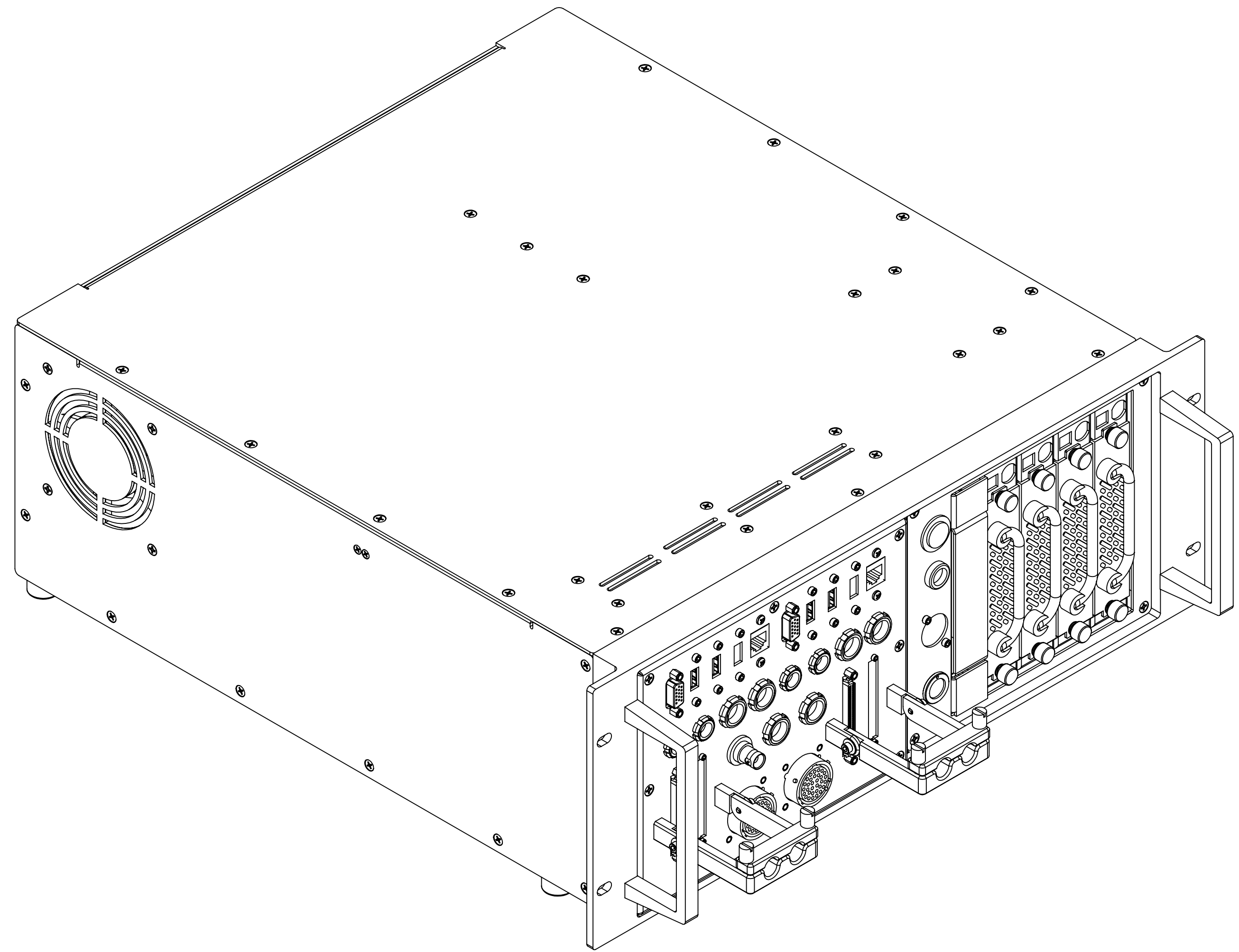

PROPRIETARY AND CONFIDENTIAL
 THE INFORMATION CONTAINED IN THIS DRAWING IS THE SOLE PROPERTY OF IRES RESEARCH LIMITED. ANY REPRODUCTION IN PART OR AS A WHOLE WITHOUT THE WRITTEN PERMISSION OF IRES RESEARCH LIMITED IS PROHIBITED.

UNLESS OTHERWISE SPECIFIED: DIMENSIONS ARE IN INCHES TOLERANCES: FRACTIONAL ± 1/32 ANGULAR ± 5 DEGREE TWO PLACE DECIMAL ± .01 THREE PLACE DECIMAL ± .005 SURFACE FINISH: 63 OR LESS		DRAWN	DATE	NAME	 110, 3553 31ST STREET NW CALGARY, ALBERTA T2L 2K7 TEL: 403 250 9944 FAX: 403 250 9916
	CHECKED	4/11/2011	FH	TITLE:	
	ENG APPR:			ICU, DUAL PRO, QUAD RECORDING, SATA, IEI (EXTERNAL DIMENSIONS)	
	MFG APPR:			SIZE DWG. NO. REV	
	G.A.			D 02084001 1	
	COMMENTS:			SCALE: 1:2 WT: SHEET 1 OF 1	
MATERIAL:	N/A				
FINISH:	N/A				
NEXT ASSY:					
USED ON:					
APPLICATION:					

02084001

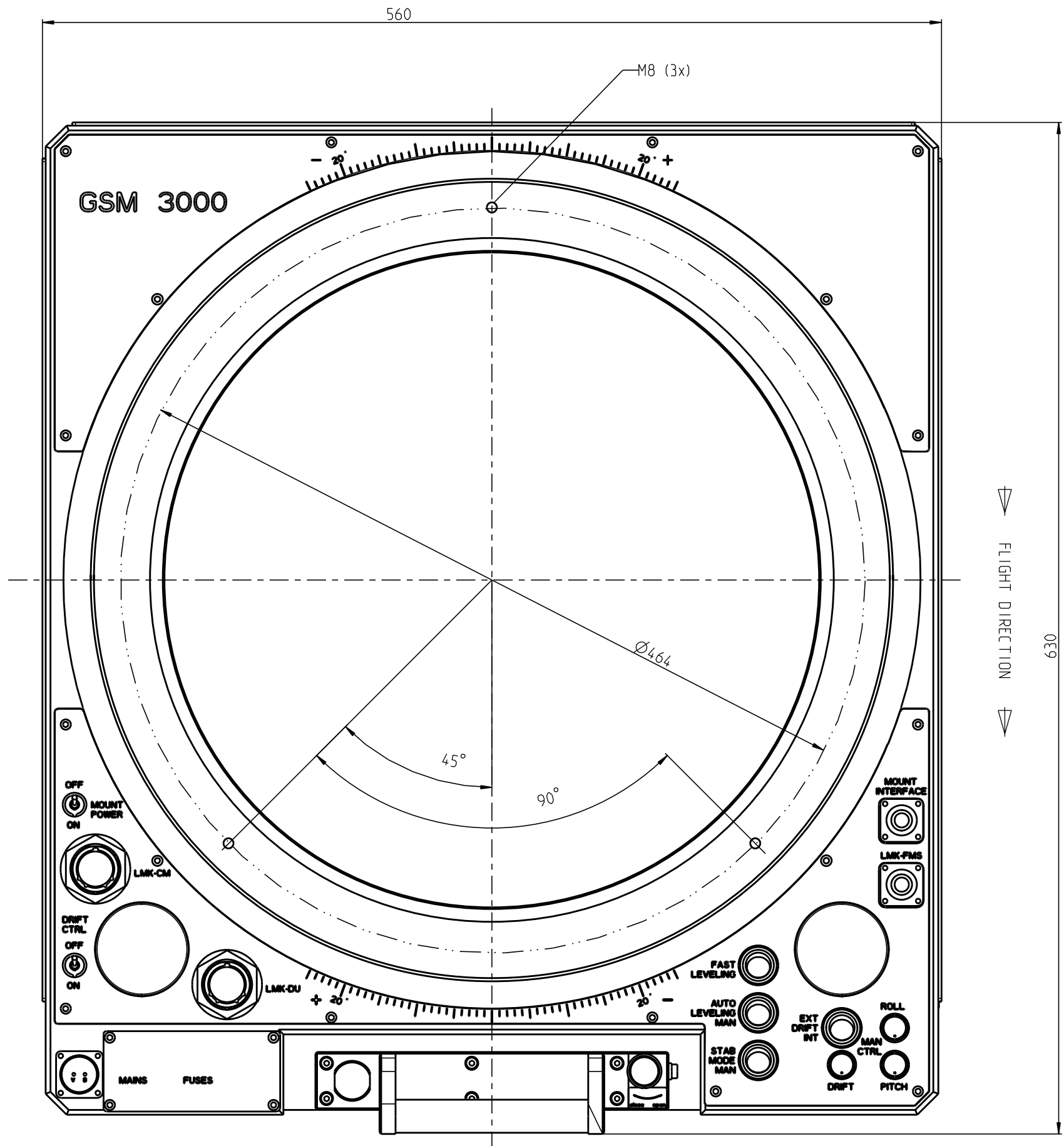

G S M 3 0 0 0

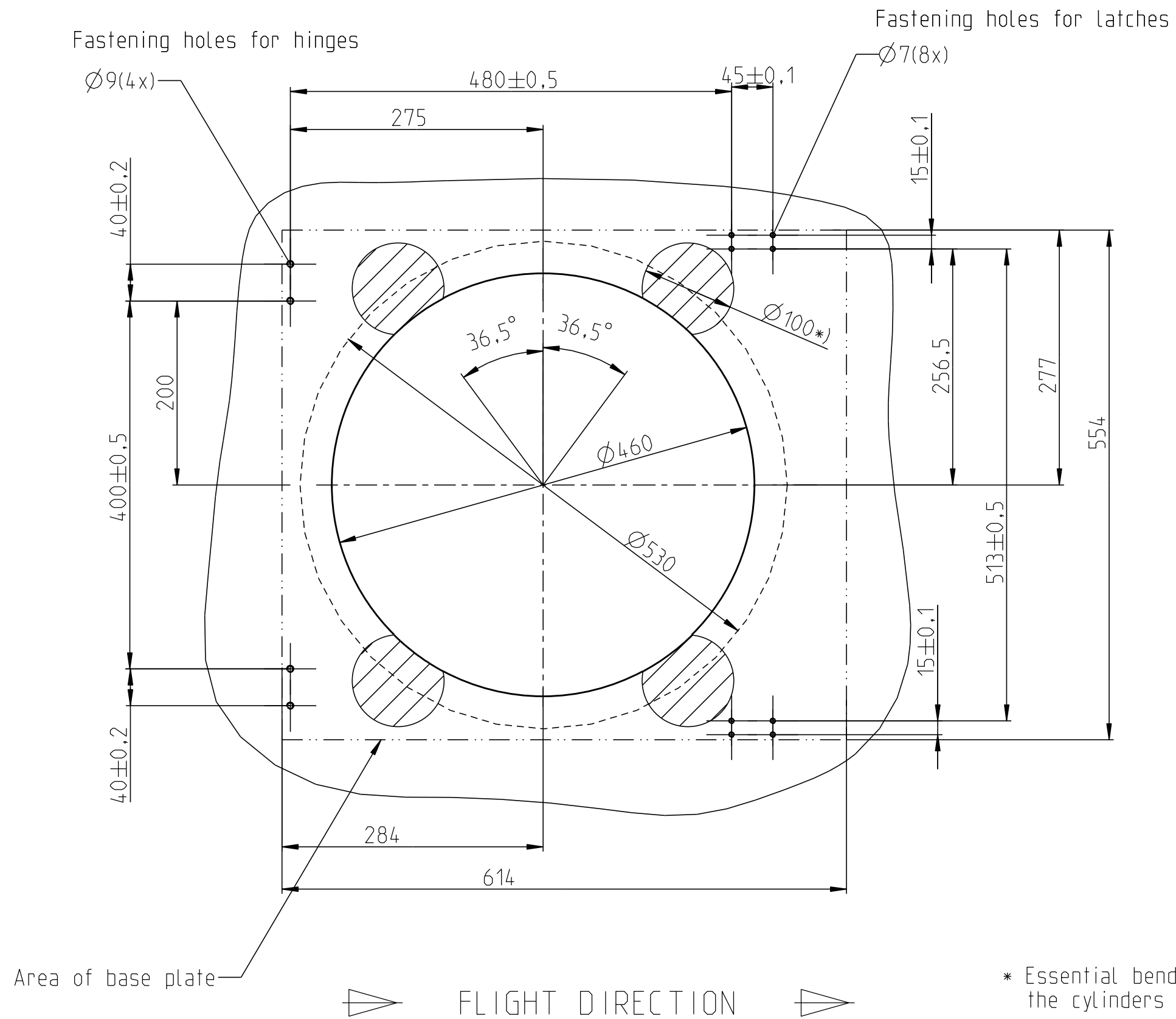

G S M 3 0 0 0

Dimensions for installation in airplane

SOMAG-AG-Jena Teichmann 31.01.2004